

※ 尺寸/Dimensions 单位/Unit: (mm)

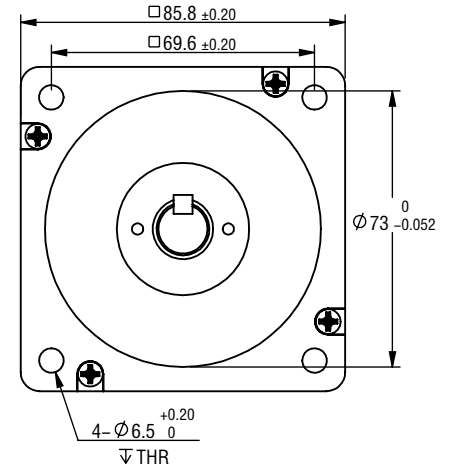
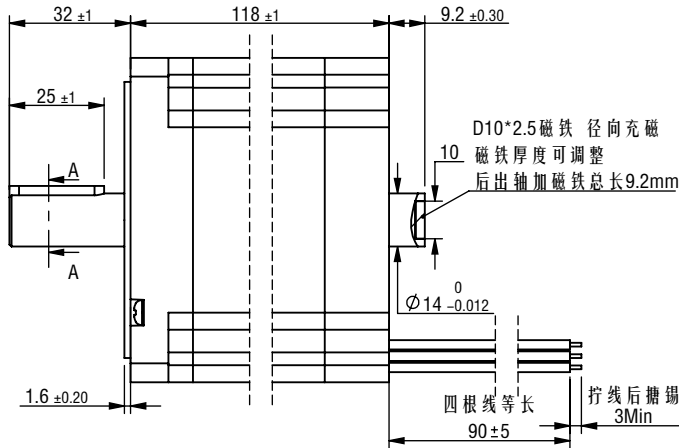
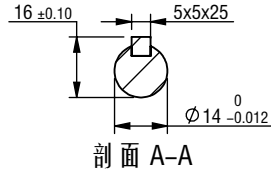
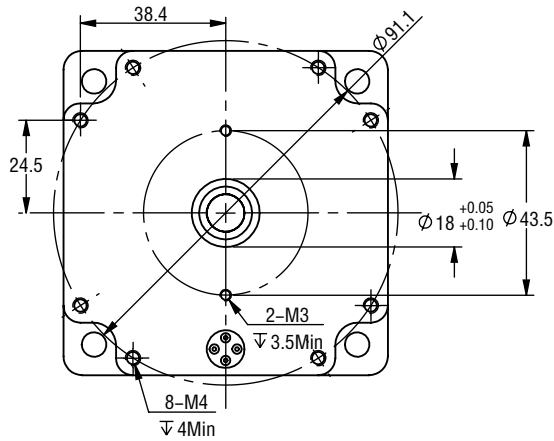

※ 电机规格/Motor Specification

相数/No. of phase	2 相/phase
步距角/Basic step angle	1.8°
步距角误差(空载)Positional accuracy(no-load)	±0.09° 以下/Max
额定电流/Rated current	6.0 A
保持扭矩/Holding torque	8.5 N.m
相电阻/Phase resistance	0.5 ± 10% ohm(20°C)
相电感/Phase inductance	4.2 ± 20% mH(1KHz)
转子惯量/Rotor inertia	≈ 2800 g.cm ²
重量/Weight	≈ 4.1 Kg
绝缘耐压/Dielectric strength	500V A.C
绝缘电阻/Insulation resistance	100MΩ 以上/MIN
绝缘等级/Insulation class	B
使用温度范围/Operation ambient temperature	0°C~+50°C
使用湿度范围/Operation ambient humidity	20%RH~90%RH
保存温度范围/Storage ambient temperature	-20°C~+70°C
保存湿度范围/Storage ambient humidity	15%RH~95%RH

※ 接线图/Wiring diagram

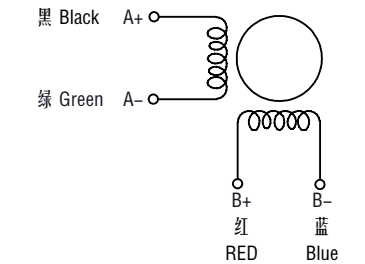

※ 励磁顺序 (2相励磁)
Phase sequence(2 phase exciting)

Step	A	A-	B	B-
1	+	+	-	-
2	-	+	+	-
3	-	-	+	+
4	+	-	-	+

CW ↓ CCW ↑

※ 铭牌内容
Label description

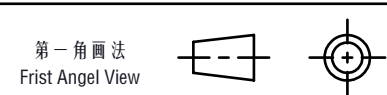

名称/Name
两相步进电机
2 phase stepping motor

型号/Model
IC86A85-K4J60D09

公差/Tolerance	比例/Scale	页码/Sheet	客户型号/ Customer model
±0.3	1:2	1/1	客户品号/ Customer Product No.

制图/Drawn	Name	Date	设计/Design	Name	Date
审核/Checked			批准/Approved		

LEESN 深圳市立三机电有限公司
立三机电 Shenzhen Lisan Machinery & Electric Co., Ltd